

# Touch Series

# Model: Touch-HWN



Blue Back Lit Screen	Y	°C / °F Option	Y
5/2 Day Programming Mode	Y	Built In Sensor	Y
7 Day Programming Mode	Y	Remote Air Sensing Mode	N
Number of Heating Levels	4	Floor Sensing Mode	N
Optimum Start	Y	Remote Probe Included	N
Number of HW Times	4	Max Switching Current	3A
Holiday Function	Y	Accuracy	+/-1°C
Keylock Function	Y	Adjustable Switching Differential	0.5 - 3°C
Temperature Hold Function	Y	<b>Supply</b>	<b>12VDC</b>
Temperature Override	Y	<b>Rating</b>	<b>3A</b>
Temperature Override Limit	Y	<b>Installed Dimensions (L,H,D)</b>	<b>100 x 110 x 16.5mm</b>
Frost Protection	Y	<b>Weight</b>	<b>189g</b>
Networking Facility	Y		

## Feature Table

FEATURE	DESCRIPTION	SETTING
01	Temperature Format	00 = °C, 01 = °F (°C = Default)
02	Switching Differential	0.5° - 03°C (Default 1.0°C)
03	Frost Mode	00 = Disable, 01 = Enabled (01 = Default)
04	Frost Protection Temperature	07° - 17°C (Default 12°C)
05	Output Delay	00 - 15 Minutes (00 = Default)
06	Communications ID No.	Set unique comms address (01-32)
07	Up/Down Temperature Limit	00° - 10°C (00 = Default)
08	Sensor Selection	Built in Sensor Only
09	Floor Temperature Limit	Not used on this model
10	Optimum Start	00 -03 Hours (00 = Default)
11	Rate of Change	Minutes to raise by 1°C
12	Program Mode	00 = Weekday/Weekend, 01 = 7 Day Programming

## Product Dimensions (mm) & Wiring Specification

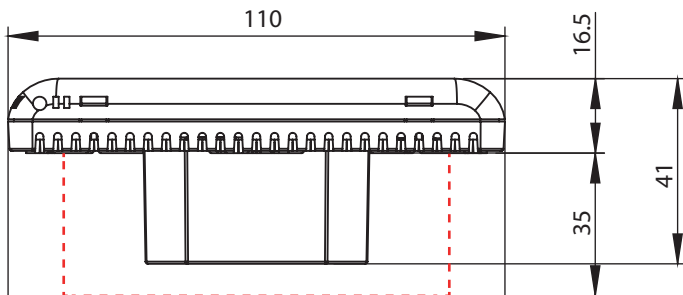

Note: Fits standard 35mm depth back box

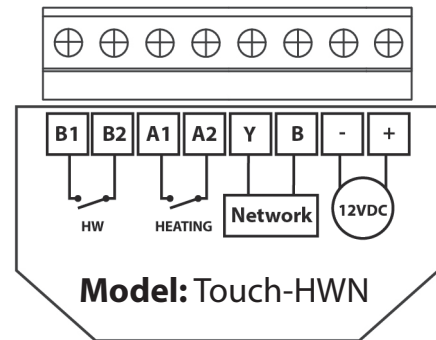
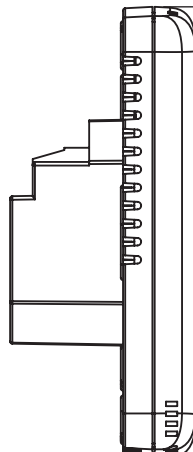
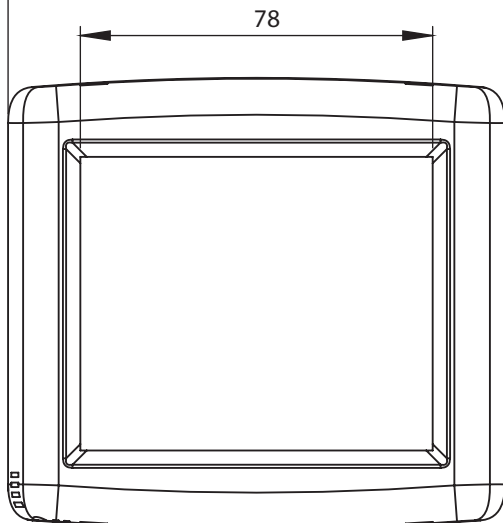

Wiring Detail

